

Complementary valves Series 900

Pressure switches

Impulse generators

Timers

Two hands safety valve

Valve

Oscillator valve

Signal amplifier

Progressive start up valve



General

When building automated pneumatic circuits, it is sometimes necessary to alter or modify the various signals. There can be, for instance, a permanent signal coming from a limit switch that needs to be terminated, or there may be a need to modify a pneumatic signal into an electric one, etc. While this can be accomplished by using commercially available components, the process is tedious and expensive. We have therefore developed a number of components to facilitate this task resulting in a consistent saving of time, space and money.

The 900 series consist of the following components:

- Pressure switch, which transforms a pneumatic signal into an electric one.
- Impulse generator, which transforms a permanent pneumatic signal into an adjustable impulse from 0 to 10 seconds.
- Pneumatic timer (N.C. or N.O.), which cuts or releases a pneumatic signal within an adjustable time.
- Two hands safety valve, which allows a safety use of two hands pneumatic controls (for example two push-button 3/2 N.C. to a certain distance) excluding false signals in case of push-button or valve malfunction.
- Oscillator valve, 5/2 - G 1/8" with two logic functions "NOT" mounted on board, switches when the pressure in the connected cylinder exhaust chamber is reaching the threshold of "NOT".
- Signal amplifier, 3/2 - G 1/8" N.C. valve actuated by weak signals but higher than 0.05 bar.
- Progressive start-up valve, which is a device that is fitted in between valve or solenoid valve and cylinder allows a gradual filling of the chamber providing a low power cylinder movement. The progressive start-up valve is made of a flow control valve and a 2/2 N.C. valve with 6 mm nominal orifice. The valve is totally open when the pressure in the cylinder reaches 50% of inlet pressure.
- High-low pressure devices, located in the pneumatic circuit between valve and cylinder, allow the function of the cylinder with two different pressures. Example: in case of a locking action, it is possible to approach the required position at a low pressure, then increase to its maximum value in the circuit with the use of an electric signal. They are practically made of a piloted pressure regulator without relieving.

Construction characteristics

We have not listed all different materials used for the construction of these components because the list would be too long. We use corrosion proof material, brass or anodized aluminium and the most appropriate specific mixture for seals. If more information is required please contact our technical department.

Use and maintenance

In use pay attention to the minimum and maximum criteria for temperature and pressure, checking and ensure good quality compressed air. In a dirty environment, protect the exhaust ports. In this case, maintenance is minimal and is necessary only if the air is particularly dirty. The components most subject to damage by the accumulation of dirt are flow regulators with fine regulation and silencers. As for regulators, follow the normal procedure for disassembling, washing with non-chemical cleaning agents and remounting. The silencers need only to be rinsed in petrol or solvent and blown dry with compressed air.

The number of requests for spare seals for flow regulators and shuttle valves are statistically irrelevant. More often, it is necessary to replace the lining of the quick exhaust because of the wear it undergoes due to the particular conditions of operating.

ATTENTION: for lubrication use class H hydraulic oils, for example Castrol MAGNA GC 32.



Pressure switch
G 1/8" - screw connections

Ordering code

900.18.1-1 (0,5 ÷ 1 bar)
900.18.1-4 (3,5 ÷ 4 bar)

Weight gr. 75

Pressure switch
G 1/8" - spade connections

Ordering code

900.18.1/1-1 (0,5 ÷ 1 bar)
900.18.1/1-4 (3,5 ÷ 4 bar)

Weight gr. 60

Switch protection

Ordering code

900.18.0

Weight gr. 6

Operational characteristics	Fluid	Max working pressure	Operating temperature		Working pilot port size	Flow rate microswitch 900.18.1/1	Flow rate microswitch 900.18.1
	Filtered and lubricated air	10 bar	min. -5°C	max. +70°C	G 1/8"	13 (3) A - 220 V~	16 (5) A - 220 V~

Impulse generator

Ordering code

900.18.2 N

Weight gr. 235

Operational characteristics

Fluid	Max working pressure	Operating temperature		Ø Orifice size
Filtered and lubricated air	10 bar	min. -5°C	max. +70°C	mm 2

Pneumatic timer N.C. G 1/8"

Ordering code

900.18.3 (0 ÷ 30 seconds)
900.18.3-60 (0 ÷ 60 seconds)

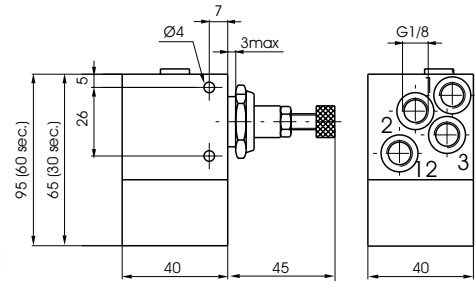
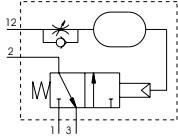

Weight gr. 290 (30 sec.)
 Weight gr. 350 (60 sec.)

Operational characteristics

Fluid	Max working pressure	Operating temperature		Flow rate at 6 bar $\Delta p = 1$ bar	Ø Orifice size
		min.	max.		
Filtered and lubricated air	3 ÷ 10 bar	-5°C	+70°C	130 NI/min.	mm 2,5

Pneumatic timer N.O. - G 1/8"

Ordering code

900.18.4 (0 ÷ 30 seconds)
900.18.4-60 (0 ÷ 60 seconds)

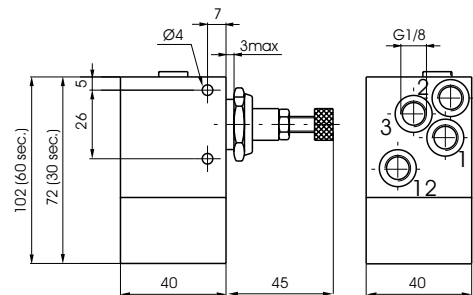
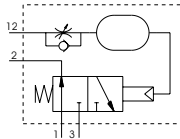

Weight gr. 320 (30 sec.)
 Weight gr. 380 (60 sec.)

Operational characteristics

Fluid	Max working pressure	Operating temperature		Flow rate at 6 bar $\Delta p = 1$ bar	Ø Orifice size
		min.	max.		
Filtered and lubricated air	4 ÷ 10 bar	-5°C	+70°C	130 NI/min.	mm 2,5

Two hands safety valve G 1/4"

Ordering code

900.52.1.1

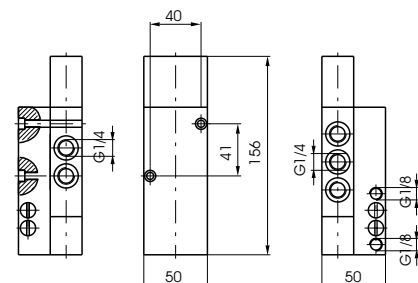
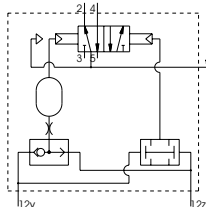

Weight gr. 780

Operational characteristics	Fluid	Max working pressure	Operating temperature		Flow rate at 6 bar with $\Delta p = 1$	Ø Orefice size	Working port size	Working pilot port size
	Filtered and lubricated air	10 bar	min. -5°C	max. +70°C	1030 NI/min	mm 7	G 1/4"	G 1/8"

Flip-flop valve G 1/8"

Ordering code

900.52.1.2

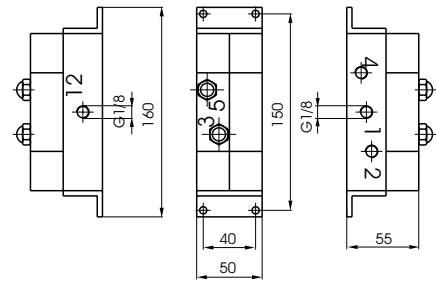
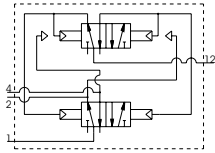

Weight gr. 970

Operational characteristic	Fluid	Max working pressure	Operating temperature		Flow rate at 6 bar with $\Delta p = 1$	\varnothing Orefice size	Working port size
	Filtered and lubricated air	10 bar	min. -5 C	max. +70 C	540 NI/min	mm 6	G 1/8"

Oscillator valve G 1/8"

Ordering code

900.52.5
(without logic functions NOT)
900.52.5C
(with logic functions NOT)

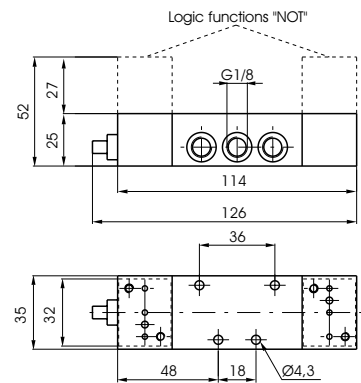
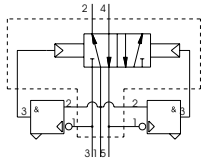

Weight gr. 600

Operational characteristics	Fluid	Max working pressure	Min working pressure	Operating temperature		Flow rate at 6 bar $\Delta p = 1$	\varnothing Orefice size	Working port size
	Filtered and lubricated air	8 bar	2 bar	min. -5 C	max. +45 C	540 NI/min	mm 6	G 1/8"

Signal amplifier G 1/8"

Ordering code

900.32.6

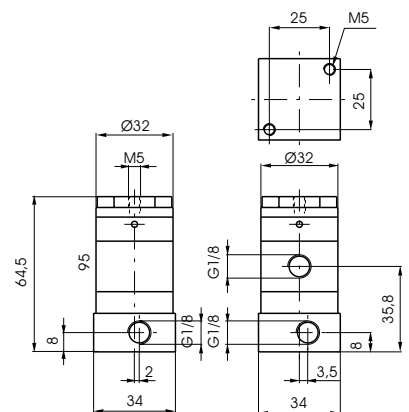
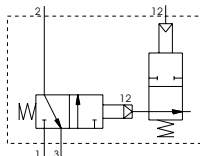

Weight gr. 170

Operational characteristics	Fluid	Max working pressure	Min working pressure	Operating temperature		Flow rate at 6 bar $\Delta p = 1$	\varnothing Orefice size	Working port size
	Filtered and lubricated air	10 bar	0,05 bar	min. -5 C	max. +45°C	130 NI/min	mm 3	G 1/8"



**Progressive start-up valve
G 1/4"**

Ordering code

900.14.7

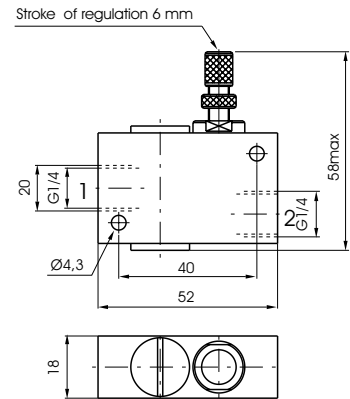
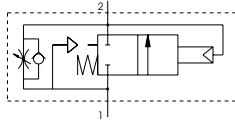

Weight gr. 100

Operational characteristics	Fluid	Min / Max working pressure	Operating temperature		Flow rate from 1 to 2	Flow rate from 2 to 1	Flow rate needle fully open from port 1 to 2	Ø Orifice size	Working port size
		Filtered and lubricated air o non	2,5 / 10 bar	min. -5°C	max. +70°C	760 NI/min	900 NI/min	200 NI/min	mm 6

High-low pressure device

Ordering code

900.18.8P
(with pneumatic pilot)

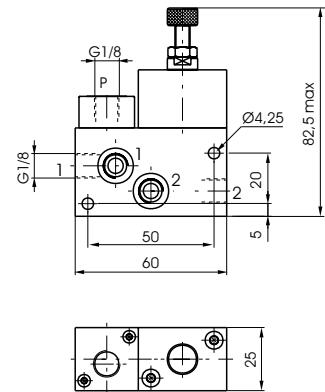
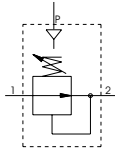

1 = Inlet / pressure gauge
2 = Outlet / pressure gauge
P = Piloting

Weight gr. 240

Ordering code

900.18.8E
(with M2 mechanic)

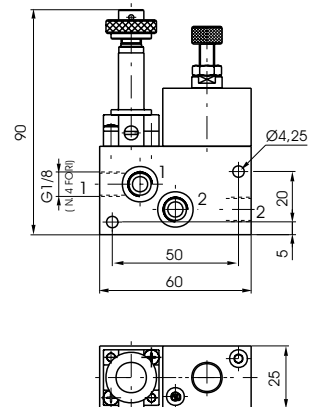
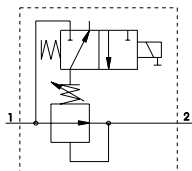

1 = Inlet / pressure gauge
2 = Outlet / pressure gauge

Weight gr. 280.

Operational characteristic	Fluid	Max working pressure	Pressure range	Temperature		Max flow 6 bar Δ p = 1	Connections
		Filtered and lubricated air	10 bar	1 ÷ 4 bar	min. -5°C	max. +45°C	650 NI/min